



straightcurve®

Specifications

400mm Flexline™

LENGTH 2160mm | TOP THICKNESS 8mm

FINISHES

-  Galvanised Steel
-  Weathering Steel

SOLD AS SET INCLUDING

- ✓ 1 x Joining set (3 x wedge, 3 x slider, 1 x joint bracket)
- ✓ 5 x galvanised spikes, 300mm long

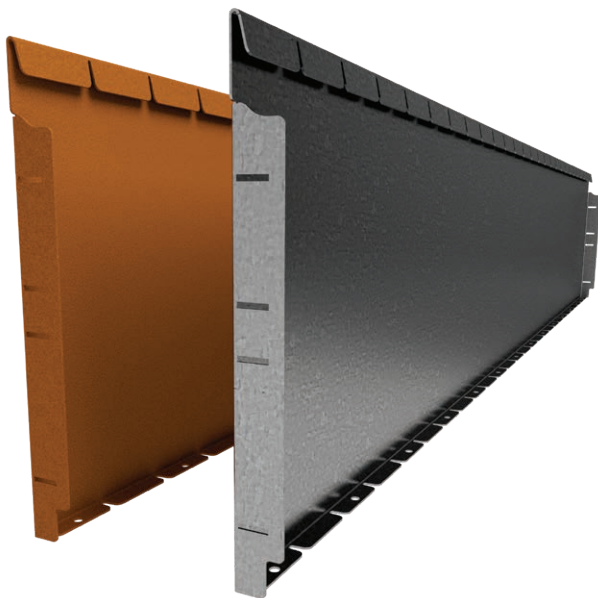
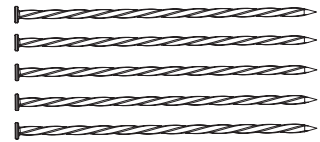
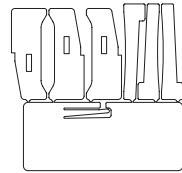

Steel plate thickness 2mm

ADDITIONAL ACCESSORIES

REQUIRED

- ✓ Bracing set OR
- ✓ Large Anchor set (6 x Tek Screws 12G x 16mm)

OPTIONAL

- ✓ Corner piece (arm lengths: 255mm)
- ✓ Joining sleeve (8 x Tek Screws 12G x 16mm)

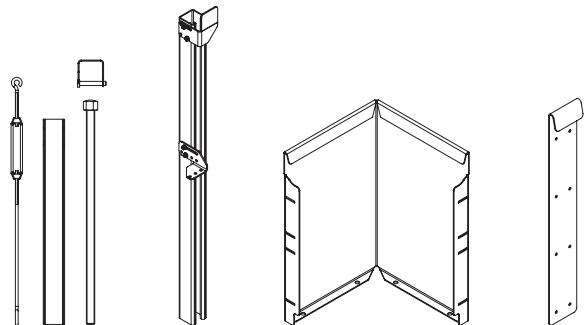

Installation guide 400mm Flexline™

Scan me for
Video installation!



Scan the code or follow the link below for installation video.
400mm Flexline™ installation video

PREPARATIONS

Mark line and level or trench as required ready for install.

Note: This edge allows gentle sloping

CORNERS

Standard corners are available for purchase and recommended*, these include the standard joining set. These can be opened or closed further with forceful bending to achieve different angle corners. You can also choose to make your own. To do this score a line down the back of the edge and create a sufficient opening (5-7mm) in the folded lip at the top and cut out part of the foot at the bottom with your angle grinder to allow space for bending. Bend strongly by hand; using a block of wood close to the fold helps.

JOINING SLEEVES

Shortening a length is sometimes a requirement. The joining sleeve is used to connect the two edges when this occurs. These are fixed to the panel front with screws through the guide holes in the sleeve.

BRACING*

Two methods for bracing are available. The bracing sets will work well in hard ground situations or when quick set concrete is utilised. The anchor sets are more appropriate in soft soil conditions. Both methods allow for adjustment of the vertical during installation. When terracing, make sure the walls are 1.5x the wall height from each other. As a minimum allow two bracing sets or anchor posts per edge length (except for closed circles of two panels, they are not required).

TIP

In soft sandy soils, a little quick set concrete around the nails makes a huge difference.

STANDARD RING SIZES

Connecting edge lengths makes standard ring sizes, use join sleeve for non-standard diameters greater than 1.5m

Lengths	Diameter
2	1.37m
3	2.06m
4	2.75m
5	3.44m

STEP 1 - JOIN

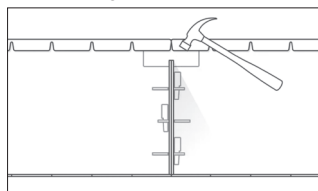

STEP 2 - FLEX

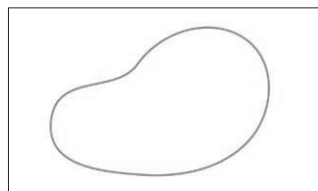

STEP 3 - PEG

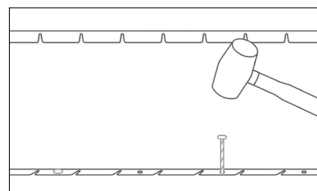

STEP 4 - BRACE*

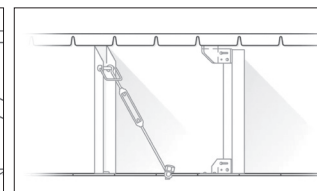

PRE-MADE CORNER**

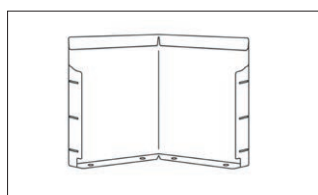

MAKE CORNER - NOTCH/SCORE WITH GRINDER

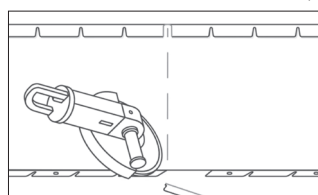

TIGHT RADIUS - STRAP

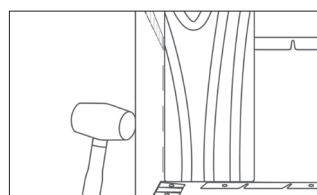

TIGHT RADIUS - STRAP

